

FIELD FABRICATED EXPANSION JOINT - FLAT TYPE DETAIL

PARASOLO HYBRID SYSTEM - RIGID INSULATION

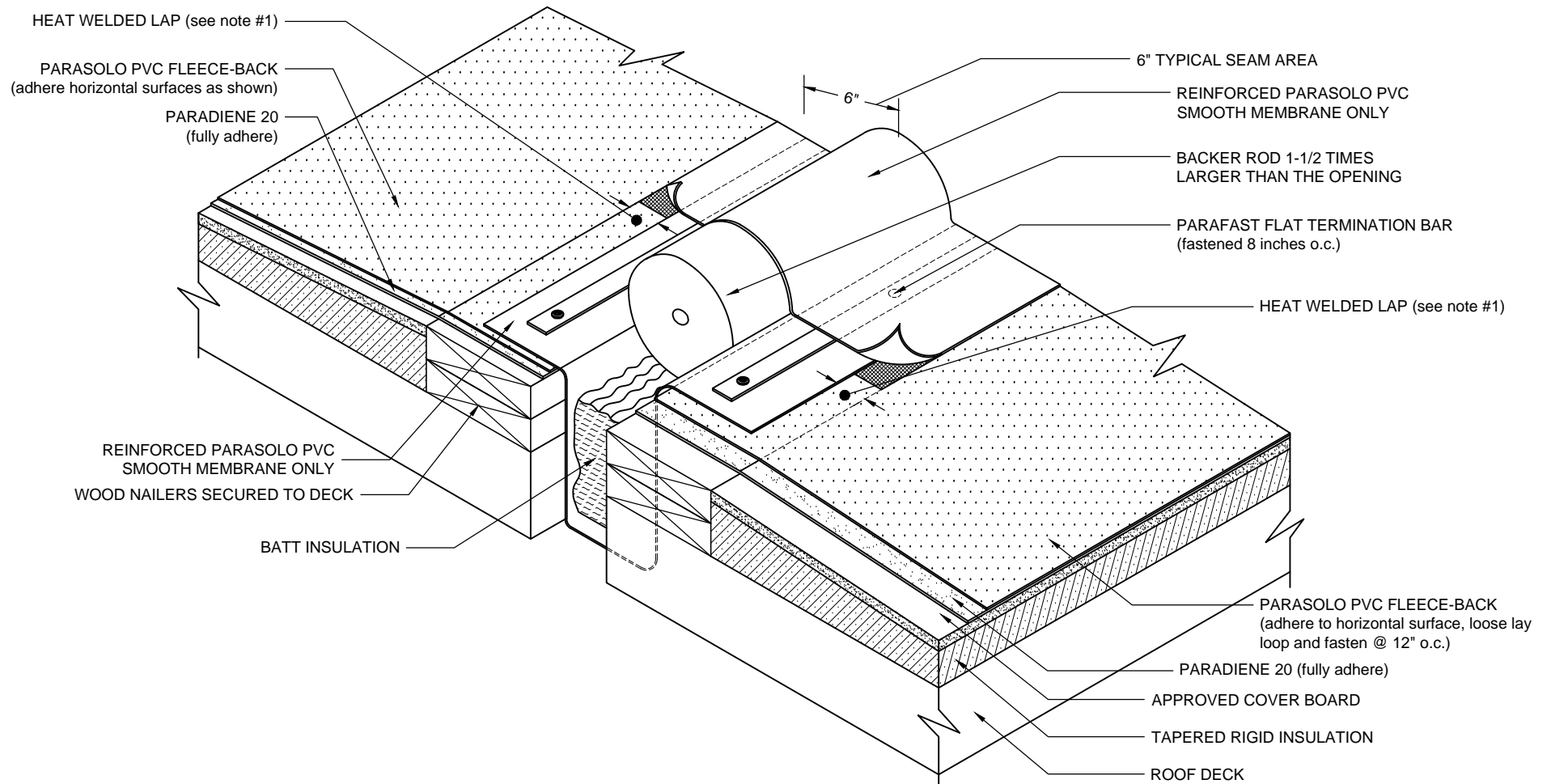

NOTES:

1. FOR HEAT-WELDING LAPS USE 1.5" MIN. WELD WITH AUTOMATIC MACHINE WELDER AND 2" MIN. WELD WITH HAND WELDER.
2. WHERE PRIMER IS INDICATED TO MAINTAIN PROPER ADHESION, TA-119 PRIMER IS REQUIRED FOR ALL PARADIENE 20 SA FLASHING REINFORCING AND STRIPPING PLY APPLICATIONS. USE PA-1125 OR PA-917 LS PRIMER FOR ALL OTHER PARADIENE 20 SERIES PRODUCTS THAT ARE NOT SELF-ADHESIVE SHEETS. CONTACT SIPLAST FOR SPECIFIC REQUIREMENTS.
3. THE METAL WORK SHOWN DEPICTS SHOP FABRICATION AND JOB-SITE ASSEMBLY. THESE COMPONENTS SHOULD BE DESIGNED/FABRICATED/INSTALLED ACCORDING TO GENERALLY ACCEPTED INDUSTRY PRACTICES, STANDARDS, AND APPROVALS.
4. REQUIREMENTS AND RECOMMENDATIONS DETAILED IN CURRENT SIPLAST SPECIFICATIONS SHALL APPLY IN ADDITION TO THE ABOVE DRAWING.

CAUTION: SIPLAST RECOMMENDS THAT ALL PRACTICES PERTAINING TO NRCA CERTA GUIDELINES BE FOLLOWED WHEN TORCHING METHODS ARE EMPLOYED. THIS INCLUDES PERFORMING A FIRE WATCH FOLLOWING ANY TORCH APPLICATIONS. ALWAYS HAVE APPROVED FIRE-EXTINGUISHING EQUIPMENT NEARBY.

N.T.S

