

FIELD FABRICATED WALL EXPANSION JOINT - FLAT TYPE DETAIL

PARASOLO PVC ROOF MEMBRANE - RIGID INSULATION (ALL SYSTEMS)

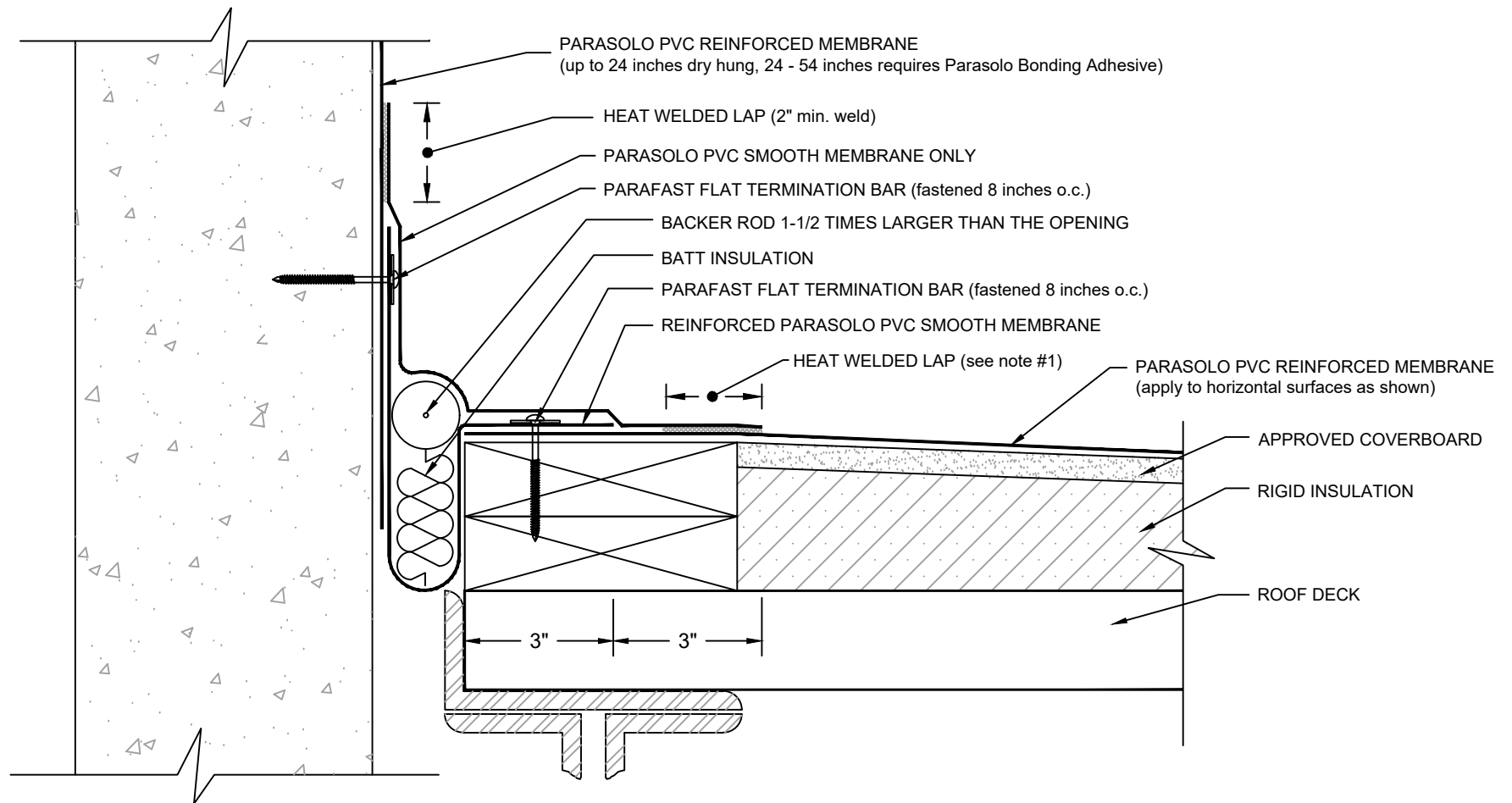

NOTES:

1. HEAT-WELDING LAPS USE 1.5" MIN. WELD WITH AUTOMATIC MACHINE WELDER AND 2" MIN. WELD WITH HAND WELDER.
2. THE CARPENTRY AND METAL WORK SHOWN DEPICTS SHOP FABRICATION AND JOB-SITE ASSEMBLY. THESE COMPONENTS SHOULD BE DESIGNED/FABRICATED/INSTALLED ACCORDING TO GENERALLY ACCEPTED INDUSTRY PRACTICES, STANDARDS, AND APPROVALS.
3. REQUIREMENTS AND RECOMMENDATIONS DETAILED IN CURRENT SIPLAST SPECIFICATIONS SHALL APPLY IN ADDITION TO THE ABOVE DRAWING.

N.T.S