

PARAGUARD M RAISED EDGE SYSTEM

PARASOLO HYBRID SYSTEM - RIGID INSULATION

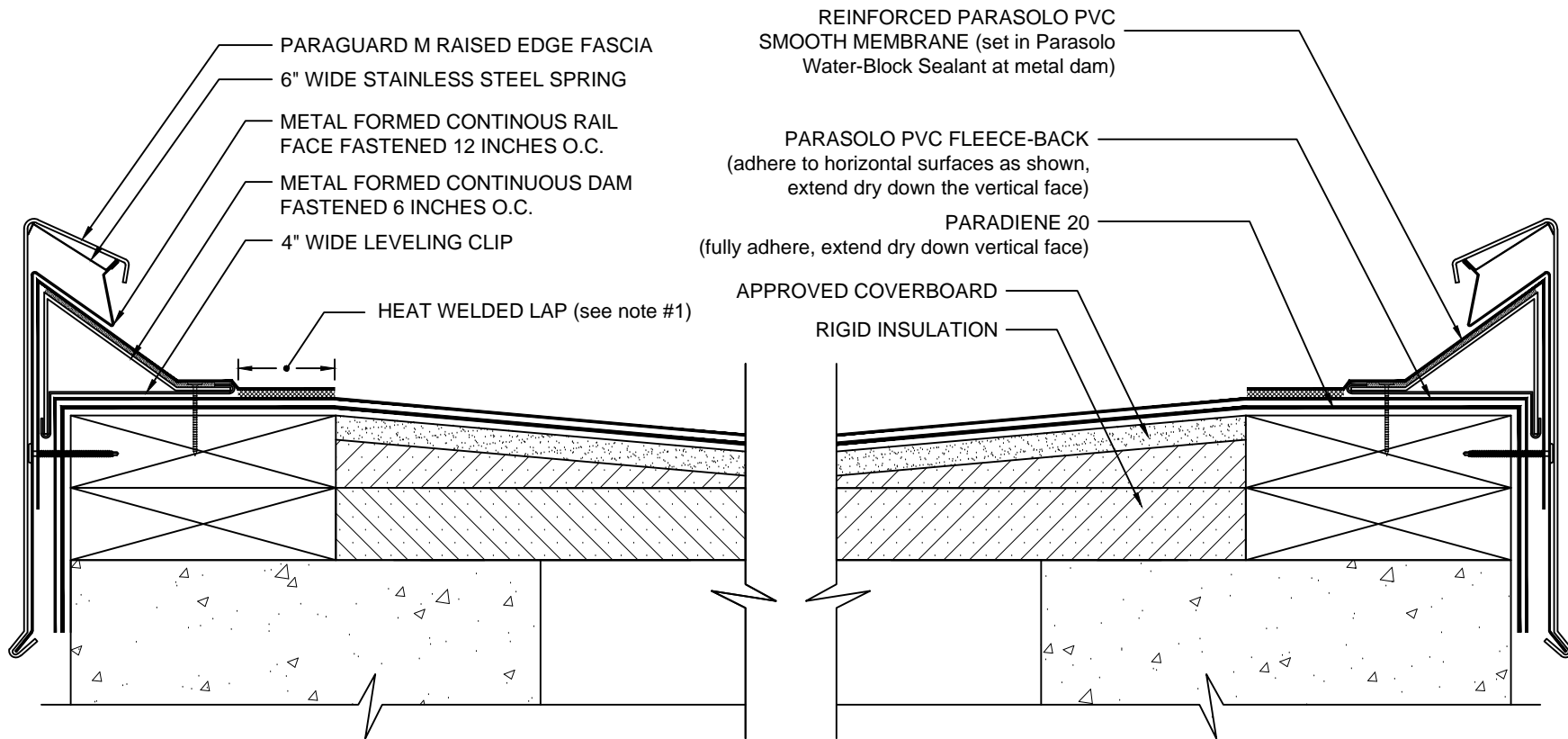

NOTES:

1. FOR HEAT-WELDING LAPS USE 1.5" MIN. WELD WITH AUTOMATIC MACHINE WELDER AND 2" MIN. WELD WITH HAND WELDER.
2. THE CARPENTRY AND METAL WORK SHOWN DEPICTS SHOP FABRICATION AND JOB-SITE ASSEMBLY. THESE COMPONENTS SHOULD BE DESIGNED/FABRICATED/INSTALLED ACCORDING TO GENERALLY ACCEPTED INDUSTRY PRACTICES, STANDARDS, AND APPROVALS.
3. THE PARAGUARD M RAISED EDGE SYSTEM DOES NOT ALLOW FOR DRAINAGE AT THE ROOF EDGE; APPROPRIATE SLOPE SHOULD BE PROVIDED AWAY FROM THE EDGE AND TOWARDS INTERNAL ROOF DRAINS.
4. REQUIREMENTS AND RECOMMENDATIONS DETAILED IN CURRENT SIPLAST SPECIFICATIONS SHALL APPLY IN ADDITION TO THE ABOVE DRAWING.

CAUTION: SIPLAST RECOMMENDS THAT ALL PRACTICES PERTAINING TO NRCA CERTA GUIDELINES BE FOLLOWED WHEN TORCHING METHODS ARE EMPLOYED. THIS INCLUDES PERFORMING A FIRE WATCH FOLLOWING ANY TORCH APPLICATIONS. ALWAYS HAVE APPROVED FIRE-EXTINGUISHING EQUIPMENT NEARBY.

N.T.S